

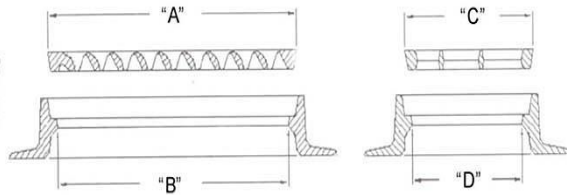

# ADS FLEXSTORM DIMENSIONAL / ORDER FORM

INLET TYPE: Raised Cast Iron Frame and Flat Rectangular / Square Grate

**FORM SQ**



A: GRATE WIDTH (LEFT TO RIGHT)  
 B: FRAME CLEAR OPENING WIDTH (LEFT TO RIGHT)  
 C: GRATE DEPTH (FRONT TO BACK)  
 D: FRAME CLEAR OPENING DEPTH (FRONT TO BACK)

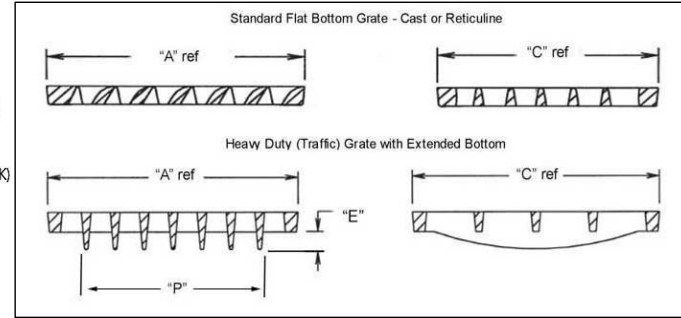

Determine Frame Size based on Clear Opening:  
 Perimeter = 2 x (B + D)

Casting or Precast Make and Model No.: \_\_\_\_\_  
 DOT Standard Callout: \_\_\_\_\_

Complete CATCH-IT P/N (galvanized frame and FX bag)	PURE Frame P/N (stainless)	Frame Sizes
62SSQFX	62SHD	<b>Small:</b> 64" max perimeter of clear opening B x D dimensions 12" x 12" through 16" x 16"
62MSQFX	62MHD	<b>Medium:</b> 96" max perimeter of clear opening B x D dimensions 18" x 18" through 24" x 24"
62LSQFX	62LHD	<b>Large:</b> 120" max perimeter of clear opening B x D dimensions 26" x 26" through 30" x 30"
62XLSQFX	62XLHD	<b>XL:</b> 168" max perimeter of clear opening B x D dimensions 32" x 32" through 48" x 48"

REF	Measured Dimensions (+/- .1")
*A	
*B	
*C	
*D	

**\* Required Dimensions. If casting or precast make and model numbers are unknown then all required dimensions must be provided and accurate to +/- .1"**

Grate Information	
Identify Your Grate Style (check one)	
Flat Bottom:	<input type="checkbox"/>
Extended Bottom "Heavy Duty":	<input type="checkbox"/>
<i>If "E" dimension extends by more than 2" please provide the "E" and "P" dimensions below.</i>	
"E" dimension:	
"P" dimension:	
Grate Part Number (if known):	

**CATCH-ITs come standard with FX bags. PURE P/N = FRAME P/N & BAG P/N**

1. ENTER YOUR PURE FRAME PART NUMBER FROM TABLE ABOVE \_\_\_\_\_

**\*\* For STAINLESS STEEL FRAMING be sure to select the PURE Frame part number**

2. ENTER YOUR DESIRED BAG PART NUMBER FROM TABLE BELOW

FLEXSTORM FILTER BAGS	(22" depth) STD Bag P/N	(12" depth) Short Bag P/N	Clean Water Flow Rate (GPM/SqFt)	Min A.O.S. (US Sieve)
FX: Standard Woven Bag	FX	FX-S	200	40
FX+: Woven w/ MyCelx	FXP	FXP-S	200	40
FXO: Woven w/ Oil Boom	FXO	FXO-S	200	40
PC: Post Construction Bag	PC	PC-S	137	140
PC+: PC Bag w/ MyCelx	PCP	PCP-S	137	140
LL: Litter and Leaf Bag	LL	LL-S	High	3.5
IL: IDOT Non-Woven Bag	IL	IL-S	145	70

3. PURE P/N = COMBINE FRAME P/N & BAG P/N: \_\_\_\_\_

REQUIRED ORDER INFORMATION	
ADS FLEXSTORM P/N:	
Qty Required:	
Ref Casting make/model or Precast make/model (if known):	
Ref DOT Standard Type / Callout (if known):	
Customer Name:	
Contact Name:	
Contact Number:	
Ref PO#:	
Ref Job Name and/or Inlet Location:	
<b>Important: If casting or precast make and model numbers are unknown then all physical dimensions are required. For help on how to measure your inlet please visit <a href="http://www.inletfilters.com">www.inletfilters.com</a>.</b>	

Filter Application (check one or both):	
During Construction:	<input type="checkbox"/>
Post Construction:	<input type="checkbox"/>

**\*\* Note: when using FLEXSTORM Inlet Filters for Post Construction requirements, ADS strongly recommends Stainless Steel Framing for 25 year life rating.**